

MAXIMUM SPAN LENGTHS	
2 AAAC	375'
123 AAAC (1/0 Eq)	450'
1/0 AAC Tree Wire	325'
246 AAAC (4/0 Eq)	450'
394 AAAC	425'
397 AAC Tree Wire	375'
652 AAAC	375'
927 AAAC	350'

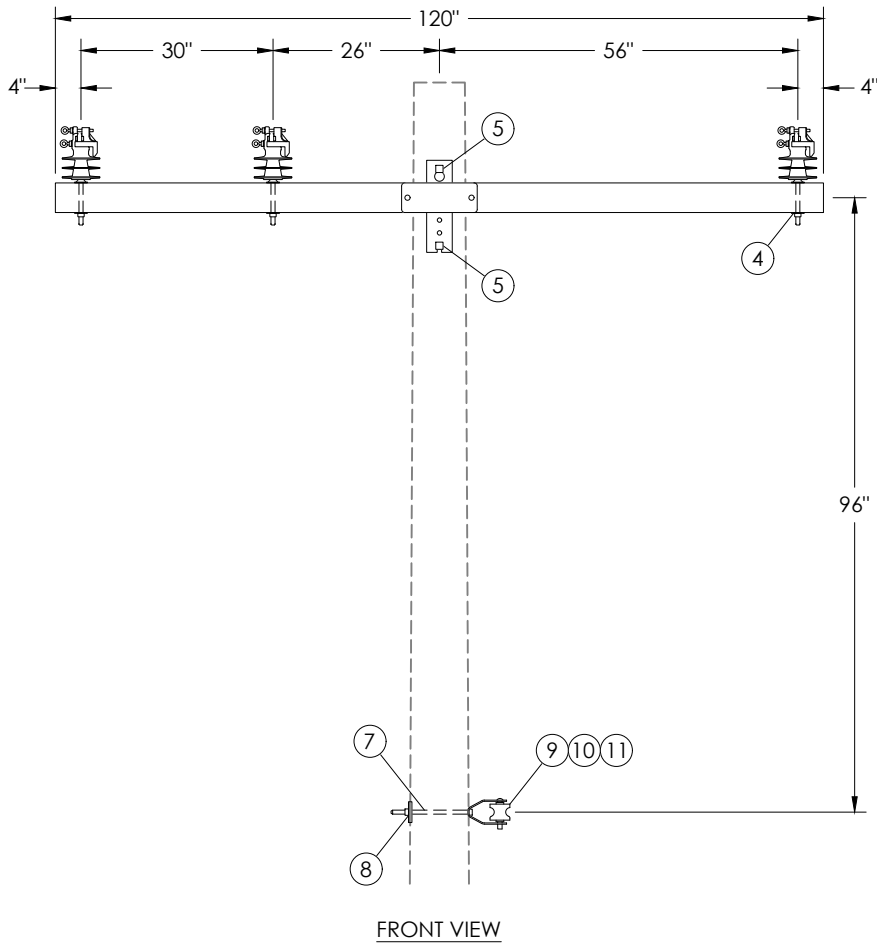

ITEM	QTY	ITEM #	MATERIAL DESCRIPTION	AU #
1	1	105207	Crossarm, FG, 10', 4-3/4" x 5-3/4", for 5/8" pins	930514
2	3	195235	Insulator, polymer pin, vise top	
3	3	230120	Pin, crossarm, 5/8" x 6-1/2", 1" nylon threads	
4	3	350210	Washer, square, 2-1/4" x 2-1/4", 11/16" hole	
5	2	120462	Bolt, machine, 3/4" x 12", with square nut	
6	2	350120	Washer, square curved, 3" x 3", 13/16" hole	
7	1	120432	Bolt, machine, 5/8" x 12", with square nut	
8	1	350110	Washer, square curved, 3" x 3", 11/16" hole	
9	1	145310	Clevis, neutral bracket	
10	1	145311	Insulator, polymer neutral spool	
11	6'	560496	Tie wire, #4 Al	

Notes:

- Contact Standards for other needed conductors or span lengths.
- Adjust bolt lengths as necessary.

	<b>STANDARDS</b>		<b>CONSTRUCTION STANDARDS</b>		REV	DATE	DESCRIPTION
	PUBLIC UTILITY DISTRICT NO. 1 Cowlitz County, Washington 961 12th Avenue Longview, Washington		3 PHASE OVERHEAD DISTRIBUTION LIGHT ANGLE, BRACELESS 10FT FG ARM, 1-5°		0	10/06/25	Initial release
Designed D. Tuominen		Checked M. Demos		Standards Approved <i>[Signature]</i>		Std/Dwg No. <b>3-514</b>	